



Item No. _____

Quantity _____

**Model No.
6750-240
Counter Top
Boiling Units**



6750-240

Nemco's pasta boiling unit cooks all types of pasta, vegetables and shell fish plus they're ideal for reconstituting food. This convenient counter top model allows you to produce one pound of spaghetti or three pounds of frozen pasta in just a couple of minutes. Initial heat up is 12 minutes and these powerful units recover almost immediately.

Special features include heavy duty baskets constructed of stainless steel with durable plastic coated handles for a cool touch. Individual servings are possible with our accessory set of six baskets. Control panel assembly is removable for cleaning and easy maintenance. Our unique front draining system allows for safe and simple draining.

Standard Features:

- Stainless steel construction
- Incalloy tubular heating elements
- Bulb & capillary thermostat with a temperature range of 100-212° F
- Indicator lights meet U.S. and International codes
- 15 minute manual bell timer
- Twin baskets with cool touch handles
- Removable control panel assembly
- Convenient front drain valve with safety lock
- Four-inch adjustable legs
- Single phase
- Six foot cord and plug provided
- One year parts and labor warranty



NEMCO Food Equipment, LTD.
301 Meuse Argonne
P.O. Box 305
Hicksville, OH 43526
Phone (419) 542-7751
FAX (419) 542-6690
www.nemcofoodequip.com

Model No. 6750-240

AIA File No.

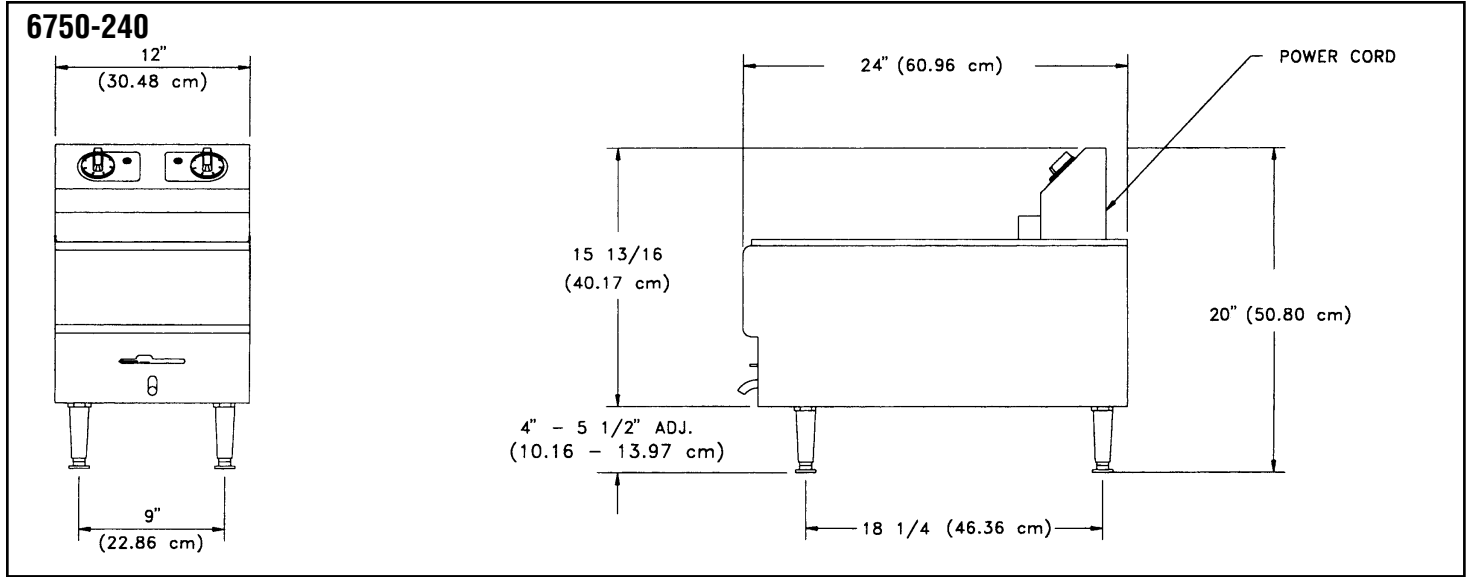

Specifications:

Model No.	Pre-heat time	Width Inches/(cm)	Depth Inches/(cm)	Height Inches/(cm)	Voltage	Rated Wattage	Nominal Amps	NEMA Configuration	Unit Weight lbs./(Kg)	Shipping Weight lbs./(Kg)
6750-240	12 min.	12 (30.5)	24 (61.0)	20 (50.8)	240	6000	25.0	10-30P plug	32 (14.6)	41 (18.6)

Accessories:

Model No.	Description
<input type="checkbox"/> 66785	Set Of Four Stainless Steel Legs
<input type="checkbox"/> 66787	Set Of Six Individual 4" x 4" x 4" Baskets

Boiling Units Performance Data:

Food Product	Basket Type	Capacity Per Tank	Quantity	Cook Time
Frozen Ravioli	Set of 6 individuals	2-1/2 Gallons	3 lbs.	3-4 minutes
Angel hair Pasta	Set of 6 individuals	2-1/2 Gallons	2 lbs.	3-5 minutes
Tubular Pasta	Set of 6 individuals	2-1/2 Gallons	3 lbs.	5-8 minutes
Fettuccini/Spaghetti	Twin Baskets	2-1/2 Gallons	1 lbs.	7-9 minutes
Broccoli/Cauliflower	Twin Baskets	2-1/2 Gallons	2 lbs.	2-4 minutes
Corn on the cob	Set of 6 individuals	2-1/2 Gallons	6 Half Ears	3-4 minutes

Typical Specifications

Electric countertop boiling unit shall have stainless steel body and heat well, and be equipped with a thermostatic control and Incalloy tubular heating element. The unit shall have a maximum heat setting of 212°F. The unit shall operate on 240 volts and have a wattage of 6000. A 6' cord and plug shall be furnished for easy installation. Boiling unit shall carry the certification of ETL testing laboratories and shall be listed with the National Sanitation Foundation.



NEMCO Food Equipment, LTD.
301 Meuse Argonne, P.O. Box 305
Hicksville, OH 43526
Phone (419) 542-7751
FAX (419) 542-6690
www.nemcofoodequip.com